

INTRODUCTION:

Ciprian offers both high-voltage and high-current amplifiers through the HVA and HCA series, respectively. Both products provide an excellent performance and are able of supplying much power to different loads. In most cases the scope of use of each type of amplifier is clear. However, in some cases the nature and value of the load can lead to a confusion about the right type of required amplifier. This note clarifies these cases, helping users to determine the most suited amplifier for their application.

DISCUSSION:

High-current amplifiers are used in applications where the loads have an extremely low impedance (a few ohms or less). Some examples are heating coils or Helmholtz coils intended for the generation of intense magnetic fields. In these cases, a high voltage is not required because a small output level already results in a very high current. In addition, high-current amplifiers require a very low output impedance because otherwise most of the output voltage would be applied to it instead of the load.

On the other hand, high voltage amplifiers operate with loads having more impedance (several tens or hundreds of ohms). This is because they provide a high voltage with a relatively moderate current. The output impedance is also low but higher than the case of high-current amplifiers due to design reasons. Typical applications of these amplifiers are ultrasonic devices, MEMs or electrooptic modulators.

The following table summarizes the relevant parameters of two amplifiers offered by Ciprian:

Model	Type	Rated voltage	Rated current	Output impedance
HVA-800-A	High-voltage	±400V	±2A	20Ω+68μH
HCA-300-A	High-current	±15V	±20A	10mΩ+2.1nH

For example, consider a load of 50nF at 1MHz. If we try to apply 400V to such load, the current required would be 125.6A. If we apply 15V, the current is 4.7A. Note that the HVA-800-A model cannot deliver 4.7A at 15V, while the HCA-300-A can do. This means that the high-current amplifier better suits this application. Because of this, it is important that the users know as accurately as possible the loads used in their applications.

EFFECT OF OUTPUT IMPEDANCES:

The latter analysis is a first approach since it neglects the effect of the output impedance. When a load is connected to an amplifier, the actual output voltage is affected by the voltage divider resulting from the output and load impedances (see Z_{out} and Z_L in the figure below). The output voltage is:

$$V_o = (G \cdot V_i) \frac{Z_L}{Z_{out} + Z_L}$$

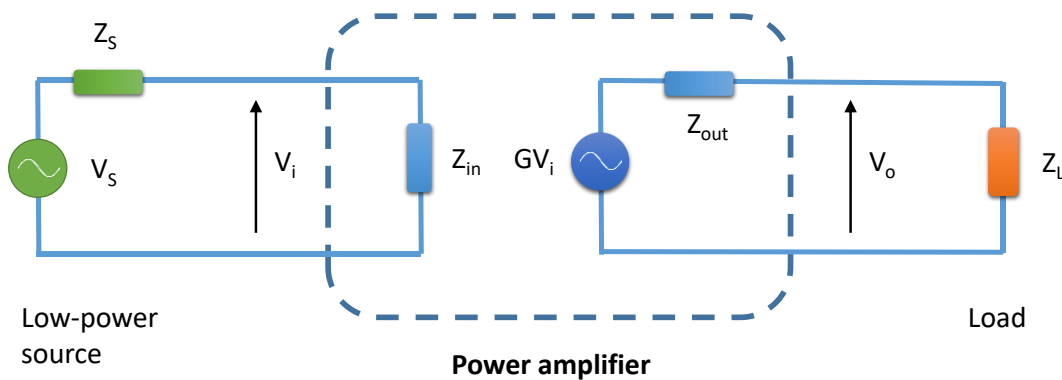

The maximum output voltage that both models of amplifier can deliver to a given load Z_L are:

HVA-800-A	HCA-300-A
$V_{o \max HV} = 400 \frac{Z_L}{Z_{outHV} + Z_L}$	$V_{o \max HC} = 15 \frac{Z_L}{Z_{outHC} + Z_L}$

Thus, the amplifier providing more power will be that obtaining a higher V_o . If we take the reasonable assumption of $Z_{out-HC} \ll Z_L$, we find that the condition where the high-current amplifier provides more power to the load is:

$$Z_L < \frac{Z_{out-HV}}{\frac{400}{15} - 1} = \frac{Z_{out-HV}}{25.67}$$

For example, in the case of the HVA-800-A at 500kHz this relation results in $Z_L < 8.36\Omega$.



Ciprian SARL
65 Chemin de Ribotière
38330 Saint Ismier
France
www.ciprian.com
contact@ciprian.com
tel. +33 476 77 17 77
fax. +33 458 00 13 10

IMPORTANT NOTICE

COPYRIGHT © 2017 CIPRIAN SARL. ALL RIGHTS RESERVED. DOMAIN NAMES, TRADEMARKS AND REGISTERED TRADEMARKS ARE THE SOLE PROPERTY OF THEIR RESPECTIVE OWNERS.

LIMITATION OF LIABILITY

INFORMATION FURNISHED BY CIPRIAN IS BELIEVED TO BE ACCURATE AND RELIABLE. HOWEVER, NO RESPONSIBILITY IS ASSUMED BY CIPRIAN FOR ITS USE, NOR FOR ANY INFRINGEMENT OF PATENTS OR OTHER RIGHTS OF THIRD PARTIES THAT MAY RESULT FROM ITS USE. SPECIFICATIONS ARE SUBJECT TO CHANGE WITHOUT NOTICE. NO LICENSE IS GRANTED BY IMPLICATION OR OTHERWISE UNDER ANY PATENT OR PATENT RIGHTS OF CIPRIAN.